



Powerful Solutions

EagleVision CCTV

SECURITY SOLUTIONS AND TECHNOLOGIES

Mini SpeedDome 3-em-1 18X IR(80m)

- Zoom Óptico 18X com Sensor SONY Starvis 1080p Low-Light
- Baixa iluminação em até 0.05Lux (Cor)/0.005 Lux (PB)/0.0Lux (IR)
- Iluminadores IR LED-ARRAY com alcance de até 80 metros
- WDR Melhor qualidade de imagem em ambientes com contraste de luz de fundo e sombras.
- Compatível com DVRs HD-AHD, HD-TVI, CVBS (Analogico)
- Conversão multi-protocolo embutida, compatível com protocolos: Pelco-D/P, EagleVision, outros.
- Controle de PTZ via cabo coaxial (Coax-UTC Control)
- 220 predefinições (podem ser rotuladas com título editável).
- 16 percursos com auto-patrolha pode ser configurados com velocidade indicada no limite de amplitude
- Função de zoom proporcional, velocidade média de rotação pode ser ajustado automaticamente de acordo com zoom
- Velocidade média em 60°/s pan e 45°/s tilt
- TVS6000w à prova de raio e alta voltagem
- Proteção para uso externo IP66 certificada

Full HD
1080p



HD 3-em-1 Sensor Sony • Visão Noturna • Zoom Óptico 18X • 220 Presets • Low-Light • WDR • Multiplas protocols • IP66



Avenida do Batel, 1230 • 5° andar
Curitiba • PR • 80420-090 • Tel: (041) 3342 1600
vendas@eaglevision.com.br • www.eaglevision.com.br





Powerful Solutions

EagleVision CCTV

SECURITY SOLUTIONS AND TECHNOLOGIES

Mini SpeedDome 3-em1 HD 2MP 18X

- A mais recente estrutura em liga de alumínio, evita choque estático
- Duplo revestimento projetado para ventilação, proteção padrão IP66
- LED-ARRAY Inteligente proporciona visão noturna em até 80metros
- Pre-sets de 220 pontos predefinidos, oito percursos e 16 posições
- Senha para limitar o acesso do operador à configuração e operação
- Proteção contra alta voltagem com proteção contra descargas elétricas
- Função dia/noite com Sensor SONY Low-Light de alta resolução 1080p
- Zoom proporcional, reduz gradualmente sua velocidade de acordo com a profundidade do objeto, tornando a imagem mais nítida e balanceando a resolução de frente e fundo.
- Dispositivo de proteção evita que os dados sejam perdidos durante falta de energia elétrica

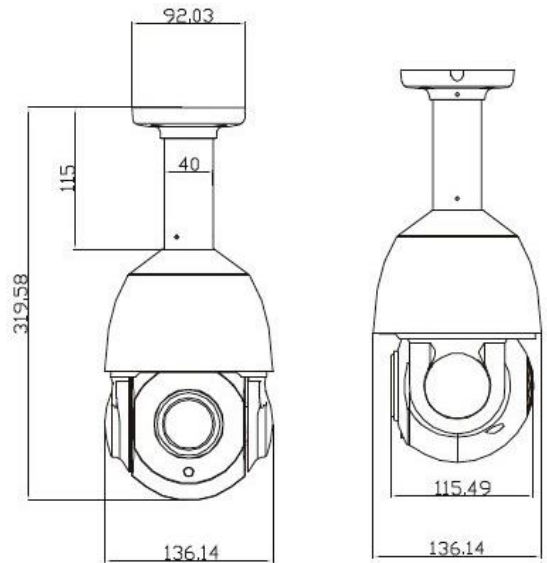

HD ANALOG SECURITY

SEE MORE CLEARLY



Seleção de Modelos Para SpeedDomes e Suportes

1	2	3	4	5
EE-	SR83		18	
		G2		W
		G5		P

- 1 – EagleVision CCTV
- 2 – SR83=SpeedDome Externa IR(80m) Série 3-em-1
- 3 – G2 = Sensor 2.1MP 1080p Full HD; G5 = Sensor 5MP
- 4 – 18 = 18X Zoom Óptico
- 5 – Tipo de Montagem:
W = Montagem de Parede; P = Montagem Pendente

HD 3-em-1 Sensor Sony • Visão Noturna • Zoom Óptico 18X • 220 Presets • Low-Light • DWDR • Múltiplos protocolos • IP66



Avenida do Batel, 1230 • 5º andar
Curitiba • PR • 80420-090 • Tel: (041) 3342 1600
vendas@eaglevision.com.br • www.eaglevision.com.br





Powerful Solutions

Especificações Técnicas SpeedDome 3-em-1 EagleVision Visão Noturna 18X

Camera		
Image Sensor	1/2.8" SONY STARVIS Low Light – 18X Optical Zoom	
Effective Pixels	1920(H) x 1080(V) 2MP Series	2592(H)x1944(V) 5M Series
Scanning System	Progressive	
Electronic Shutter Speed	1/1s ~1/10,000s	
Min. Illumination	Color: 0.05 Lux/F1.4; B/W: 0.005Lux/F1.4; 0Lux (IR on)	
S/N Ratio	More than 55dB	
Resolution	30fps@1080P/720p (HD-AHD/TVI); 960H (CBVS)	20fps@5MP/30fps@1080P/720p (HD-AHD/TVI); 960H (CBVS)
Video Output	1-channel BNC video output/ CVBS standard definition video output (3-in-1 HD Video and UTC Control)	
Camera Features		
3-in-1 Video output	HD-AHD, HD-TVI, CVBS	
Day/Night	Auto(ICR) / Color / B/W	
Backlight Compensation	BLC / WDR	
White Balance	Auto, ATW, Indoor, Outdoor, Manual	
Gain Control	Auto / Manual	
Noise Reduction	DNR auto/manual adjust	
Privacy Masking	Up to 4 areas	
Lens		
Focal Length	4.7mm~85mm (18x Optical zoom)	
Max Aperture	F1.4~ F2.6	
Focus Control	Auto / Manual	
PTZ		
Pan/Tilt Range	Pan: 0° ~ 360° endless; Tilt: -0° ~ 90°, auto flip 180°	
Manual Control Speed	Pan: 0.1° ~60° /s; Tilt: 0.1° ~45° /s	
Preset Speed	Pan: 100° /s; Tilt: 60° /s	
Preset	220	
PTZ Mode	3 Pattern, 16 Tour, Auto Pan, Auto Scan	
Speed Setup	Human-oriented focal length/ speed adaptation	
Power up Action	Auto restore to previous PTZ and lens status after power failure	
Idle Motion	Activate Preset/ Scan/ Tour/ Pattern if there is no command in the specified period	
Protocol	EagleVision, Pelco-P/D (Auto recognition)	
IR Distance	80m	
Audio		
Interface	Optional	
Auxiliary Interface		
UTC Control Communication	BNC / UTC Control OSD Menu and PTZ by coaxial communication	
Alarm	Optional	
General		
Power Supply	DC12V/3A (±10%)	
Power Consumption	10W, 20W(IR on)	
Working Environment	-40°C ~ 60°C / Less than 90% RH	
Ingress Protection	IP66	
Dimensions	29x28x17(cm)	
Weight	4.5Kg	