



Powerful Solutions

EagleVision CCTV

SECURITY SOLUTIONS AND TECHNOLOGIES

2 Mega-Pixel Auto Iris DC IR Lens 5-100mm

- Lente varifocal de cristal 2.0 MEGA-PIXEL
- Melhor abertura de iluminação em F1.6
- Montagem tipo C/CS 1/2.7"
- Corpo de metal oferece maior durabilidade e precisão de foco
- Lente ótica fabricada em vidro-cristal de alta resolução
- Fornecida com conector 4 pinos para Auto-Iris DC drive
- Especial para câmeras de CCTV com função dia/noite
- Filtro IR embutido para melhor visualização durante a noite



Technical Specs	EE-L2M5100DR
Sensor area image	1/2.7"
Mount type	C/CS
Mega-Pixel	2.0MP (Good for CCTV mega-pixel cameras)
IR Filter	Good for night vision application
Focal length	5.0-100mm
Aperture range	F1:1.6
Viewing angle 1/3"	Wide: 51.0°~4.8°
Focusing range	Wide: 0.2m ~ infinit Tele: 1.5M ~ infinit
Focus method	Manual with lock
Zoom method	20X Manual with lock
Iris	Auto iris DC
Size / Weight	Φ44x88x51mm / 250g

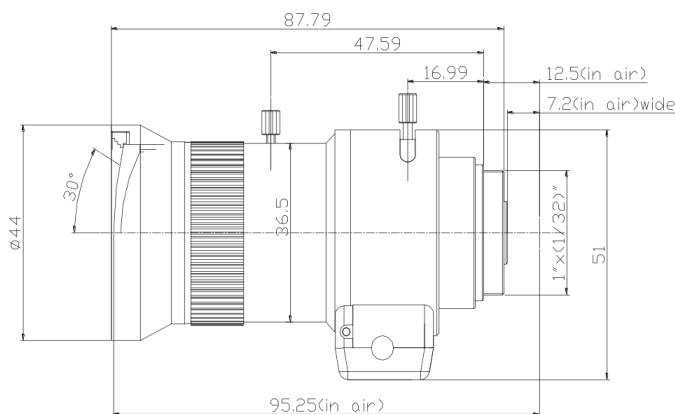

Camera Connector Wiring	
Pin	Signal
1	Brake - *
2	Brake + *
3	Drive +
4	Drive -

* Also referred to as DAMP, CONTROL, or DUMP